

Frit salvage innovation of cathode ray tube by initiating to crack along the seal edge

C. Y. Cha^{a,*}, S. V. Iyer^a, V. Lakshmanan^a, C. A. Brebbia^b & R. Adey^b

^aPhilips Display Components, Inc., Ann Arbor, Michigan USA

^bComputational Mechanics, Inc., Ashurst Lodge, Ashurst, Southampton, UK

This article describes a thermal stress boundary element analysis which was carried out to select a mechanical device that would innovate the frit salvage of cathode ray tubes (CRT). The panel and funnel of a CRT are fritted at the seal edge. To reuse a CRT, the panel and funnel are separated by etching and then applied a thermal shock. This procedure is known as frit salvage. Current yield of the frit salvage success rate is about 61%, which means that 39% of the components are lost and cannot be reused. The financial burden can be reduced if the salvage rate is improved through a better understanding of the thermal shock mechanism.

During thermal shock, a crack was observed to initiate at the end of the axes and traverses towards the corner along the seal end. A CRT is lost when the crack travels along the diagonal corner. A thermal stress analysis was carried out using the boundary element method. The analysis determined that maximum stresses are located near the blend radius on the panel skirt at approximately 1–2 inches on either side of the diagonal. Also it was found that the stresses along the frit seal edge are uniform from the end of the major and minor axes towards the diagonal. The stresses at the diagonal location were reduced by approximately 29%. The direction and location of the crack obtained by the boundary element analysis were consistent with those observed in the frit salvage procedure.

The crack's promoter along the seal edge is used to protect thermal shock on the outer face panel near the heel radius in order to prevent thermal failure on the diagonal corner. The resultant stresses' directions through the crack's promoter have two holds. The directions of the dominant high stresses at the seal edge through the crack's promoter were changed perpendicular to the seal edge. Therefore, it induces the crack to follow along the seal edge. Secondly, the stresses' directions on a diagonal corner have also been changed to be perpendicular to the seal edge. Consequently, this will prevent the crack along the seal edge from propagating to the diagonal corner, as the crack will advance normally to the maximum principal stress. The crack continues to traverse along the dominant high stress lines at the seal edge as required for a successful frit salvage process. This application is an excellent example of the advantages of using the boundary element method in an industrial setting. © 1998 Elsevier Science Ltd. All rights reserved

Keywords: Frit salvage, cathode ray tube, boundary element method.

1 INTRODUCTION

A CRT is constructed as a continuous envelope of glass. The main features of a CRT are shown in Fig. 1 by the boundary element models. Numerical techniques for the static stress analysis of engineering components have developed rapidly over the past decade, and today the two major alternatives are the finite element method (FEM)¹ and the boundary element method (BEM).^{2,3} Both techniques have been

used to carry out a stress analysis of a 27 inch CRT.^{4,5} The boundary element results achieve a high degree of accuracy even for a single element in the thickness direction. The BEM also allows remeshing of the surface easily in an extremely short period of time. In contrast, the finite element results appear to require a minimum of two eight-node brick elements in the thickness direction before the results approach analysis. The simplicity of carrying out a refined boundary discretization allows a more detailed convergence study and therefore ensures confidence in the stresses. In consequence, the boundary element model was

*Corresponding author.

THE THERMAL STRESS ANALYSIS OF 27V SALVAGE TUBE

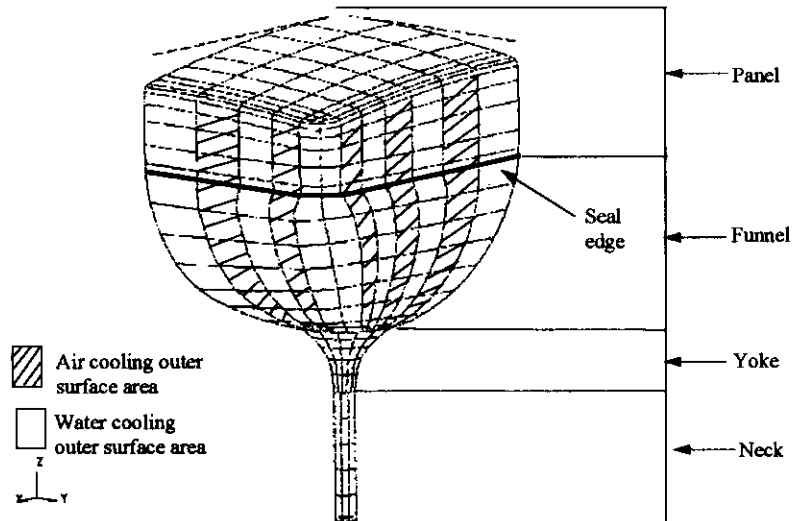

Fig. 1. Main features of 27 V tube with 3-D boundary element model.

easier and quicker to build, more accurate, and also has a much shorter modeling time than the finite element model.

2 PROBLEM

The panel and funnel of a CRT are fritted at seal edge as seen in Fig. 1. To reuse a CRT, the panel and funnel are first separated by etching the frit along the seal edge by using Nitric acid at 130°F. The glass is then cooled from 130°F to 60°F with water at 60°F in 50 s. During thermal shock, a crack was observed to initiate at the end of the axes and traverse toward the corner along the seal end. However, 33% of the CRTs are lost because of the crack traveling along the diagonal corner as shown in Fig. 2a.

In order to analyze the mechanism which caused the crack, BEM was chosen resulting from its ease of use and its well known suitability for solving problems involving cracks and stress concentrations.⁶ A thermal stress analysis was carried out using the commercial boundary element code BEASY.⁷ Two planes of symmetry are assumed, allowing only one quarter of the full tube to be modeled. A heat transfer analysis was first carried out to determine the temperature variation throughout the CRT during thermal shock. A cooling rate of 84°F min⁻¹ was assumed to simulate the actual process of cooling from 130°F to 60°F in 50 s.

A thermal stress analysis was then carried out using the temperature solutions from the heat transfer analysis. All stresses in this paper indicate maximum principal tensile stress. The thermoelastic response of the CRT was analyzed using BEASY. For this study, an approximate solution was obtained by first determining the surface temperature distribution from a heat transfer analysis which included the volume source, and then applying that temperature portion of the solution for a thermal stress analysis. The assumption

was made that the through thickness effects of the volume source is small, and that the term in the elasticity equations which considers the volumetric effects of the source temperature profile is negligible. This assumption is appropriate since the CRT has a comparatively thin section.

A quarter symmetry three-dimensional boundary element model of the CRT shown in Fig. 1 consisted of 542 continuous quadratic elements and has 8374 equations. The CRT is assumed homogeneous and isotropic with the following glass material constants (Corning Glass code 9061):

Young's modulus = 10.07 E + 6 psi

Poisson's ratio = 0.23

Thermal conductivity = 1.4 E-5 BTU/in s⁻¹ °F

Thermal expansion coefficient = 5.5 E-6 in/in °F

Reference temperature = 68°F

Volume source = 2.854 E-3 BTU/in³ s⁻¹

Heat transfer coefficient of water with the ambient temperature 60°F at outer glass surface = 1.543 E-3 BTU/in² s⁻¹ °F

Heat transfer coefficient of air with ambient temperature 130°F at inner glass surface = 2.55 E-5 BTU/in² s⁻¹ °F

Heat transfer coefficient of air with ambient temperature 60°F at outer glass = E-5 BTU/in² s⁻¹ °F

The rubber crack's promoter along the seal edge was attached to the outer face panel near the heel radius. The dominant higher stripes principal stress direction along the seal edge by the water cooling through it, will be perpendicular to the seal edge. Therefore, it was applied during the water thermal shock process and will initiate the crack along the seal edge.

Two different heat transfer coefficients were prescribed on the outer glass surface of the CRT as shown in Fig. 1 when the crack's promoter along the seal edge is used. On

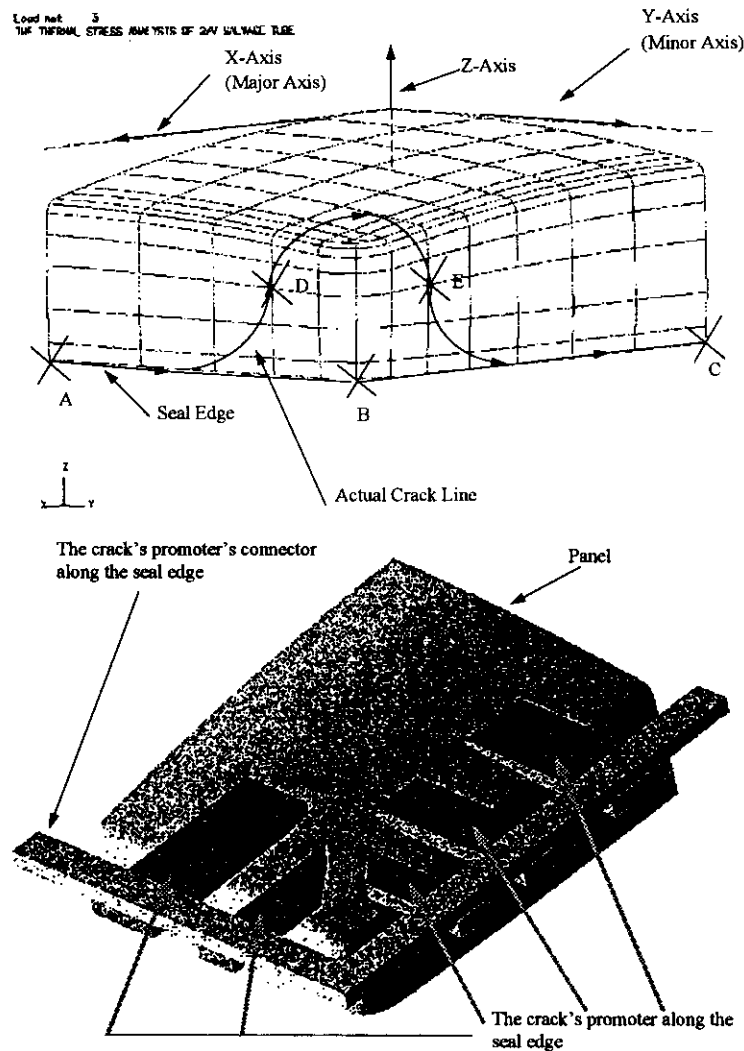

Fig. 2. (a) Detailed description of the panel. (b) The crack's promoter along the seal edge with panel.

the hatched outer surface area the heat transfer coefficient of air was prescribed while the unhatched area water was used. When the crack's promoter along the seal edge is not used, then the heat transfer coefficient of the outer surface is water.

3 RESULTS

The temperature solution over the outer glass surface is shown in Fig. 3. The entire outer surface is subjected to a temperature of 60°F. The temperature variation over the inner glass surface is shown in Fig. 4. The temperature of the inner face panel is 119°F and gradually decreases to 60°F at the neck area. This temperature variation is very reasonable since the thickness of the face panel is much larger than that of the neck.

The principal stress solutions of the outer glass surface is tensile, as shown in Fig. 5. The principal stress solution of the inner glass surface is compressive and the figure is not shown because of the whole compression uniformity of the

surface. The crack will always begin on the outer glass surface since the stress is tensile and glass is a very brittle material. Fig. 6 shows an enlarged view of the stresses over the outer panel surface since this is the crack growth region. A detailed description of the outer panel shown in Fig. 2a indicates various locations (A–E) for studying crack growth. The results of the stress analysis of the panel at various outer surface locations for the salvage tube with and without the crack's promoter along the seal edge can be seen in Table 1.

The + and – signs in Table 1 indicate the amount of increased and decreased principal stress, respectively, on salvage tube with the crack's promoter along the seal edge. The principal stress directions on the outer glass surface are shown in Fig. 7. The crack starts at point A (on major axis), (see also Fig. 2a) which has the maximum stress value (3323 psi), and proceeds along the seal edge. The crack then changes direction towards point D instead of point B (seal edge) since the stress of point D is 524 psi greater than point B. This is consistent with Fig. 7 since the crack propagates perpendicular to the principal stress

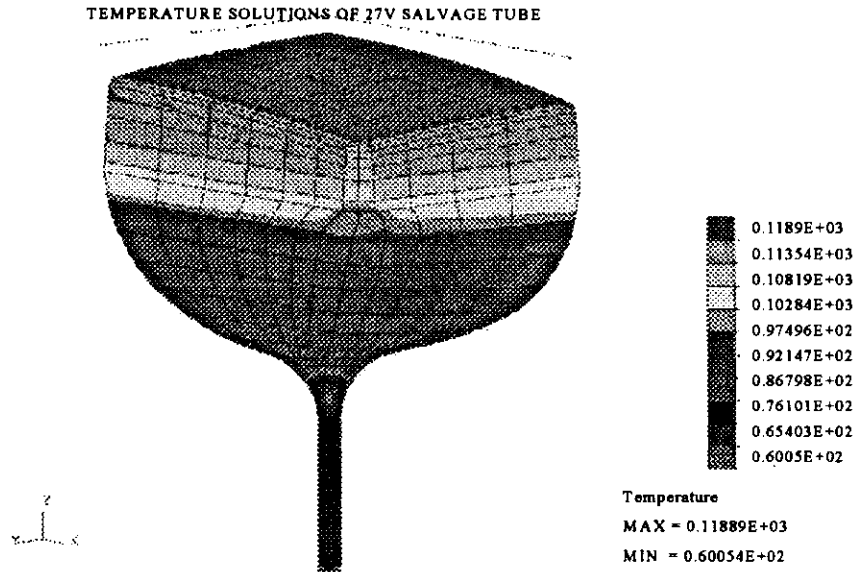

Fig. 3. Temperature solutions of outer glass surface.

direction at point D. The crack then continues to propagate towards point E and then proceeds to the seal edge and then along the seal edge to point C. This result closely matches the frit salvage process at Philips Display Components Company.

A thermal shock is applied by pouring water at 60°F on the outer centre face of the panel. Water flows over the entire outer surface of the CRT except for the hatched area of the panel and funnel as shown in Fig. 1. Water does not flow on the hatched surface area since it is diverted by the crack's promoter along the seal edge as shown in Fig. 2b. However, water does flow on non-hatched surface area

since by the natural gravity law of Newton, it is not diverted by the crack's promoter along the seal edge as shown in Fig. 2b.

The dominant higher stripe's principal stresses' directions along the seal edge by the water cooling which is non-hatched surface will be perpendicular to the seal edge. This will be explained in detail later.

It is an essential part of frit salvage innovation. As the outer glass crack at the seal edge will be continuous along the seal edge caused by the perpendicularity of the dominant higher stripe's principal stresses' directions to the seal edge.

The panel and funnel were included as an air cooling

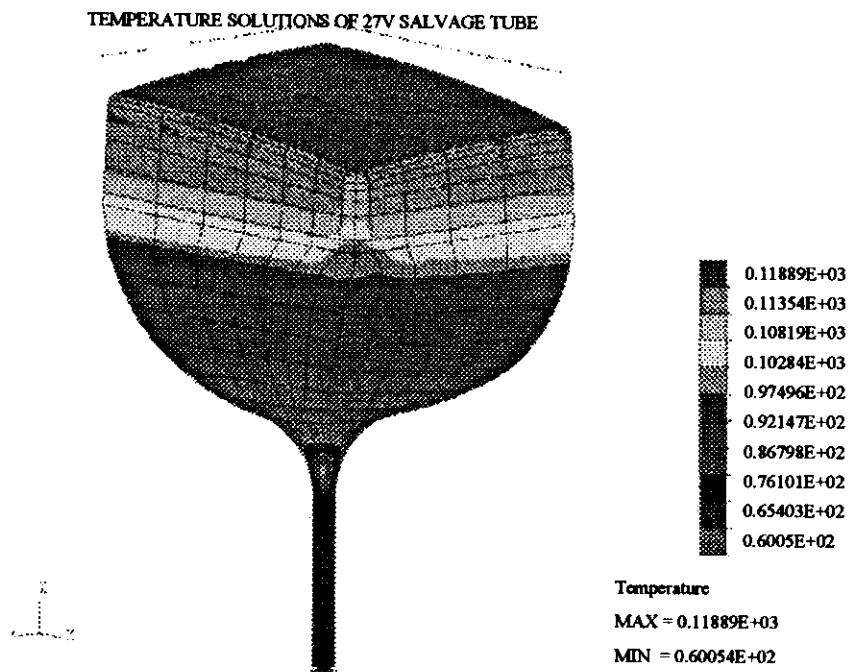

Fig. 4. Temperature solutions of inner glass surface.

THE THERMAL STRESS ANALYSIS OF 27V SALVAGE TUBE

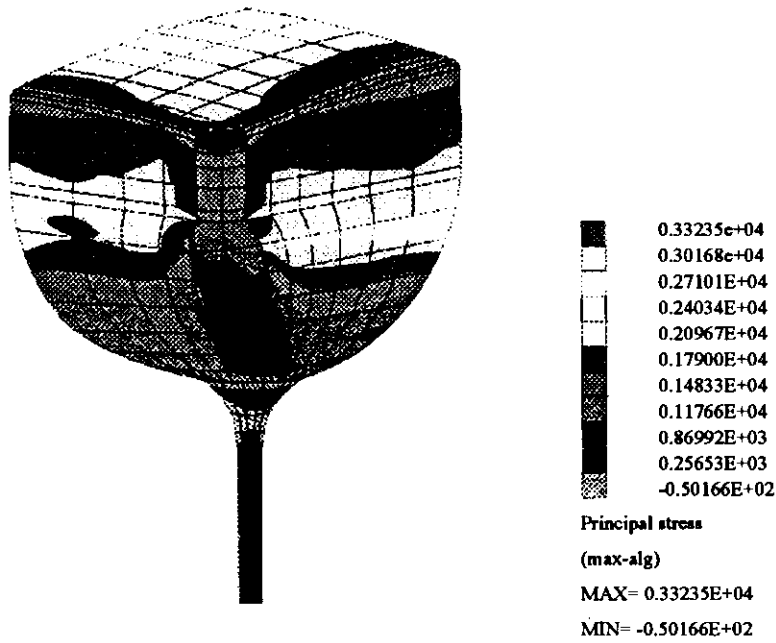

Fig. 5. Principal stress solution of outer glass surface.

portion, while air cooling on the yoke and neck surface area below the corner panel pullout protector, was neglected. This assumption is reasonable since the effects of this surface area on the seal edge is negligible because the large distance of the yoke and neck from the seal edge. The temperature solution of outer glass surface with the crack's promoter along the seal edge is shown in Fig. 8. Two kinds of stripes' temperatures on the side of the panel exists. The relative higher temperatures of the stripes with approximately 107°F by the air's cooling, are located below the crack's promoter along the seal edge. The relative lower

temperatures of stripes with 60°F by the water's cooling are located, except below the crack's promoter, along the seal edge. The temperature solution of inner glass surface with the crack's promoter along the seal edge is shown in Fig. 9.

The temperatures of the panel and funnel below the crack's promoter along the seal edge are relatively higher than the rest of it (Figs 8 and 9).

The principal stress solutions of outer glass surface with the crack's promoter along the seal edge are tensile (Fig. 10).

THE THERMAL STRESS ANALYSIS OF 27V SALVAGE TUBE

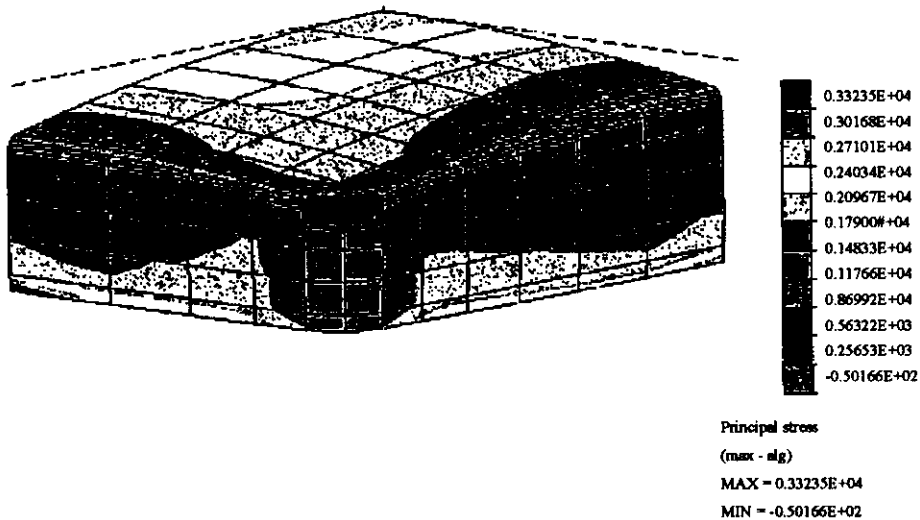

Fig. 6. Principal stresses of outer panel surface.

Table 1. Principal stress comparison of the outer panels between salvage tube and salvage tube with the crack's promoter along the seal edge

Mesh point locations (Fig. 2a)	A	B	C	D	E
Mesh No.	1618	1657	1680	1461	1567
The stress of salvage tube (psi)	3323	1275	2889	1799	1768
The stress of salvage tube with the crack's promoter along the seal edge (psi)	4278	1121	1304	1795	1947
The amount of stress changed (psi)	+ 955	- 154	- 1585	- 4	179

THE THERMAL STRESS ANALYSIS OF 27V SALVAGE TUBE

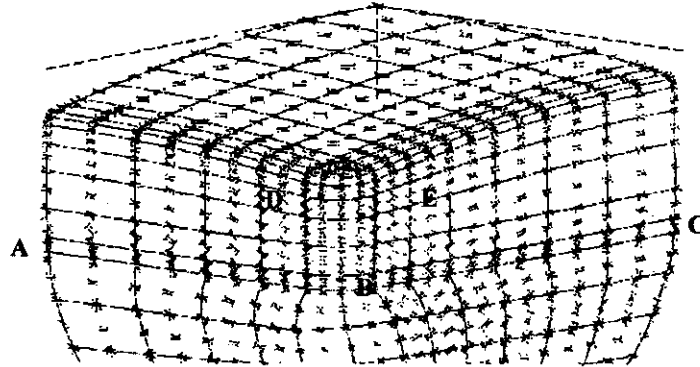

Fig. 7. The principal stress directions of outer glass surface.

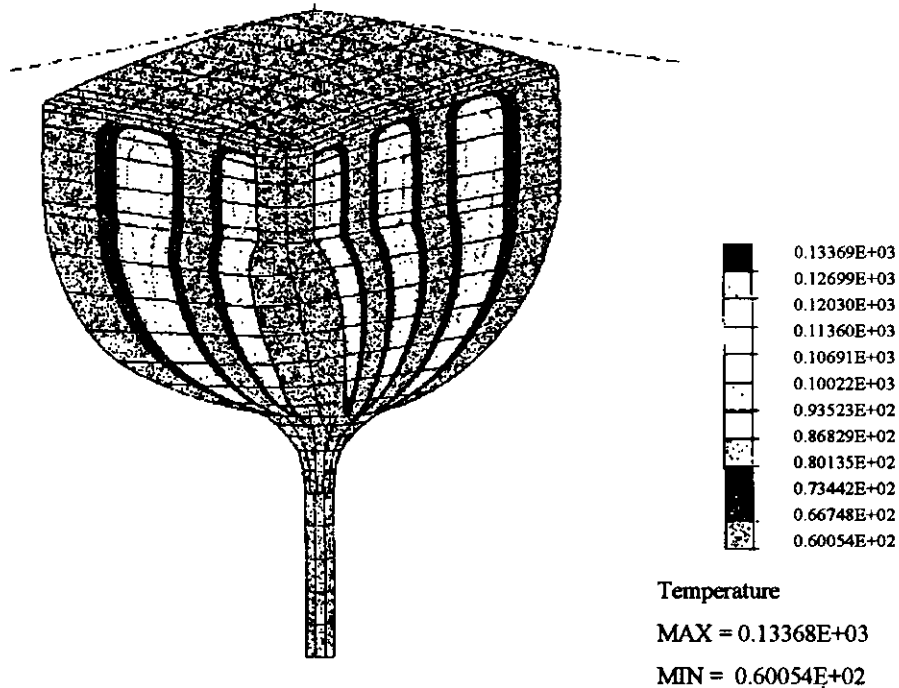

Fig. 8. Temperature solutions of outer glass surface with the crack's promoter along the seal edge.

The principal stress solutions of inner glass surface with the crack's promoter along the seal edge have compression; the figure is not shown because of the whole compression uniformity of the surface.

The principal stress of outer panel surface with crack's promoter along the seal edge can be seen in Fig. 11.

Two kinds of stripe's principal stresses on the side of the panel exist (Fig. 11). The dominant higher principal stresses of the stripes by the water's cooling are located, except below the crack's promoter, along the seal edge. The relative lower principal stresses of the stripes by the air cooling, are located below the crack's promoter along the seal edge.

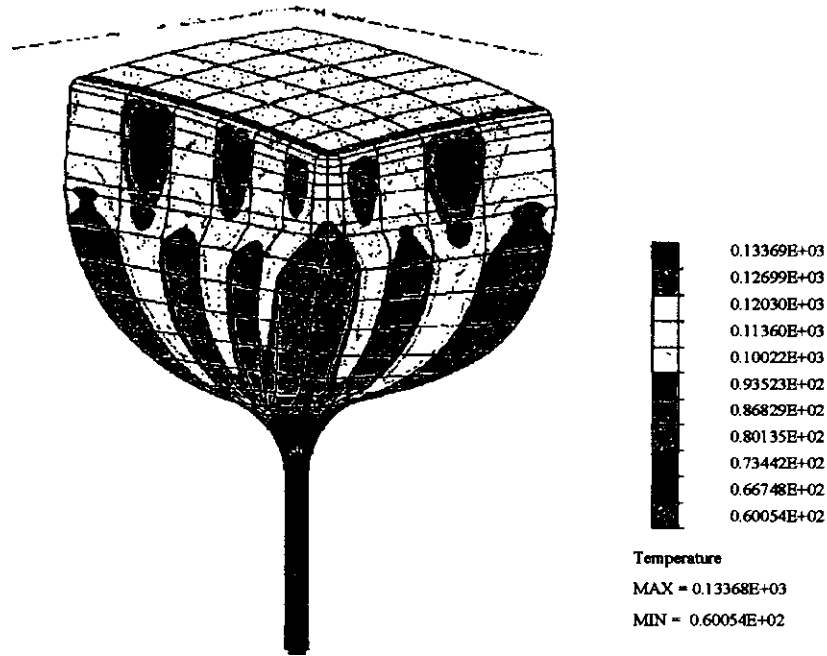

Fig. 9. Temperature solutions of inner glass surface with the crack's promoter along the seal edge.

Fig. 12 shows principal stress directions of outer glass with the crack's promoter along the seal edge. These principal stresses' directions have two holds:

1. The dominant higher stripe's principal stresses' directions along the seal edge by the water cooling, are perpendicular to the seal edge. The previous directions of principal stresses along the seal edge (Fig. 7), were not perpendicular to the seal edge.
2. The previous principal directions of stresses of D and E, which was approximately 135° and 45° respectively, with the inclination in respect to the seal edge, have been changed to perpendicular to the seal edge. This will prevent the crack along the seal edge to go to D and E points on the diagonal corner.

Resulting from the two holds, the crack will start at point A which has the maximum principal stress, then follow the dominant higher principal stripe's stresses along the seal edge and end at point C along the seal edge.

4 CONCLUSION

The direction and location of the crack obtained by the boundary element analysis was consistent with those observed in the frit salvage procedure. The crack's promoter along the seal edge was attached on the outer face panel near the heel radius to prevent thermal failure along the diagonal corner. As a result, the dominant higher principal stresses' directions of the stripes are perpendicular along the seal

edge. The principal stresses' directions at the corner are also perpendicular to the seal edge. Therefore, this will prevent the crack along the seal edge from going to Points D and E on the diagonal corner.

Consequently, the crack continues to traverse along the dominant higher principal stresses of the stripes at the seal edge as is required for a successful frit salvage process.

This new process is now being implemented at Philips Display Components Company and the experimental frit salvage success rate is 90% with improvement of

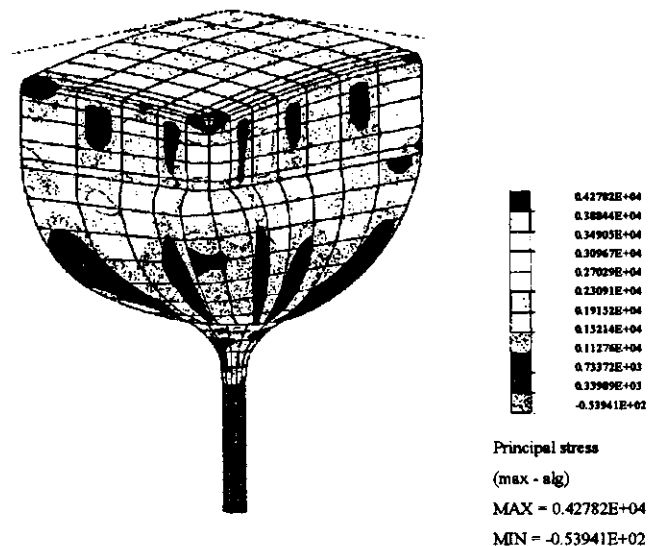

Fig. 10. Principal stress solutions of outer glass surface with the crack's promoter along the seal edge.

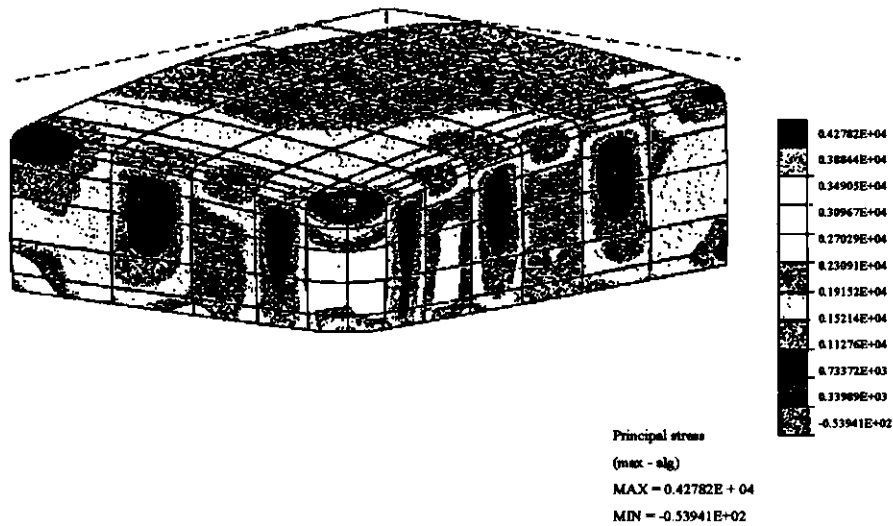

Fig. 11. Principal stress of outer panel surface with the crack's promoter along the seal edge.

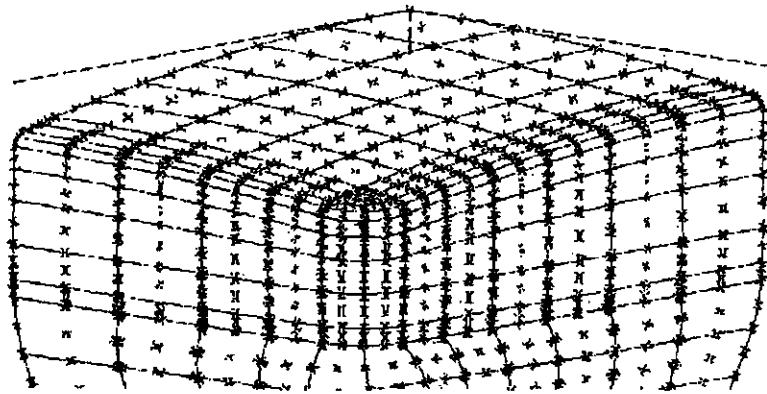

Fig. 12. Principal stress directions of outer glass surface with the crack's promoter along the seal edge.

approximately 30%. The crack propagate was observed as the path predicted.

REFERENCES

1. Reddy, J. N. *An Introduction to the Finite Element Method*, 1st edn, McGraw-Hill, New York, 1984.
2. Brebbia, C. A., Telles, J. C. F. and Wrobel, L. C. *Boundary Element Techniques*, 1st edn. Springer-Verlag, Berlin, 1984.
3. Trevelyan, J. *Boundary Elements for Engineers: Theory and Application*, Computational Mechanics Publications, Southampton, UK, 1994.
4. Cha, C. Y., Iyer, S. and Trevelyan, J. Stress failure analysis of neck breakage of cathode ray tube. *Proceedings of 17th International Conference on Boundary Element Methods in Engineering*, Vol. 1, Computational Mechanics Publications, Southampton, UK, pp. 403–419, 1995.
5. Cha, C. Y., Iyer, S. and Trevelyan, J. Comparison of convergence and modeling times for cathode ray tube stress analysis with the finite element and boundary element methods. *Boundary Element Communications*, Vol. 6, 1, Computational Mechanics Publications, Southampton, UK, 1995, pp. 1–5.
6. Aliabadi, M. H. and Rooke, D. P. *Numerical Fracture Mechanics*. Computational Mechanics Publications, Southampton, UK, and Kluwer Academic Publisher, Dordrecht, 1991.
7. BEASY, Computational Mechanics, Southampton, UK, and Billerica, MA.